

UT-301_{LT} Design Series

Up To 250 HP (187 kW) Gasoline Series

The UT-301_{LT} Design Series Universal Transmission system consists of an engine mounted, positively displaced, infinitely variable power shift transmission.

It features a patent-pending, constantly engaged, metal-to-metal drive chain with compensating Moongears™, a torque splitter, and an engaged neutral Varadriv™.



Features & Benefits

- **Increased power and torque capacity:** to mate with a wide range of high torque engines.
- **Infinitely variable ratios:** the positively displaced, constantly engaged **UT-301_{LT}** matches any engine speed without the use of a clutch or torque converter, resulting in infinite increments of ratio change.
- **Minimal dynamic friction:** the patent-pending precision drive chain design, with compensating Moongears, provides constant metal-to-metal engagement and no significant dynamic friction, resulting in increased torque capabilities above all current CVTs and greatly improved (up to 30% or more) fuel efficiency.
- **Torque management:** the torque splitter decreases wear on the transmission and results in better power utilization.
- **Engaged neutral:** achieves constant positive engagement allowing maximum torque from zero to designed infinity forward and reverse. No torque converter is needed.
- **Ease of use:** the elegant design with electronic/mechatronic controls eliminate the clutch. The operators are free to concentrate on the primary mission. Simple operation reduces training requirements.
- **Reduced downtime:** durable, robust, standard components reduce downtime. Increased machine availability and less wear and tear on other machine components assures longer life in all vehicle operations.

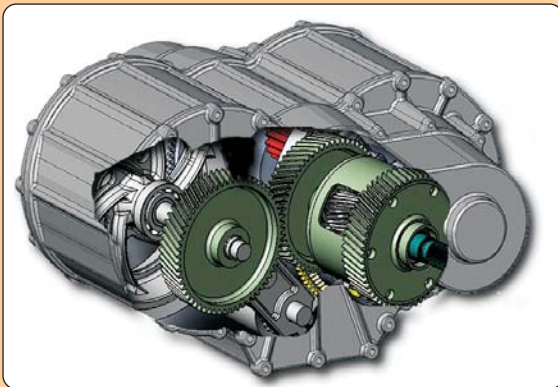

- **Drive motor controller replacement:** in hybrid and electric applications the **UT-301_{LT}** series eliminates the need for expensive motor speed controllers – thus electric/hybrid vehicles or light trucks can utilize low voltage battery systems.
- **Integrated system components:** integral power division from the torque splitter, with increased performance from the engaged precision drive chain and compensating Moongears, are all designed to work together with the engaged neutral Varadriv as a system rather than a collection of parts.

Hybrid Economy with NASCAR Performance

*Specifications subject to change without prior notice in the interest of continual product improvement.
Contact a VMT representative for engineering specifications.*





UT-301^{LT} DesignSeries

Up To 250 HP
(187 kW)
Gasoline Series



VMT puts horsepower to work by designing and engineering rugged-duty, fuel efficient, maximum torque transmission technology.

Our technology is designed to attract the most renowned manufacturers and equipment OEMs in the world

Our goal is to make your machines and vehicles more productive, fuel efficient and durable. Also making them more economical to produce and maintain, and more operator friendly than with any other transmission.

From custom design development to after sale support, VMT is totally committed to your business.

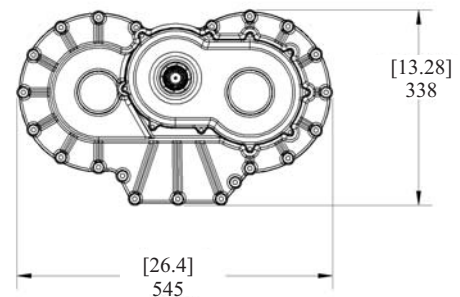
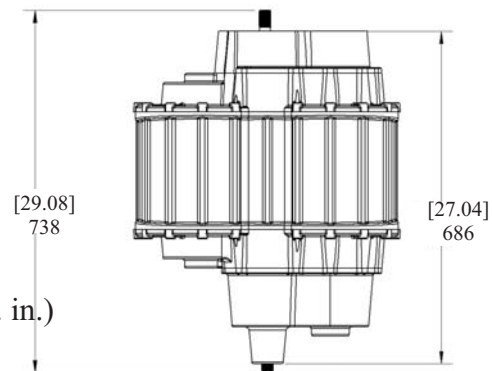
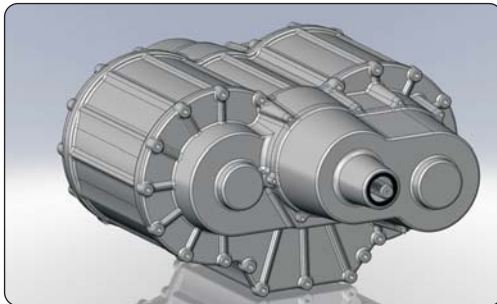

SPECIFICATIONS:

Engine range	3.5 to 6.0 L (214 to 366 cu. in.)
Maximum input horsepower	187 kW (250 hp)
Maximum engine torque	407 Nm (300 lb-ft)
Maximum input torque	610 Nm (450 lb-ft)
Maximum input speed	7500 rpm
Max. output torque (ETM, VHRL)*	2712 Nm (2000 lb-ft)
Weight	80 kg (176 lbs.)
Gear ratios forward	.59 to infinity
Gear ratios reverse	6.1 to infinity
Length	738 mm (29.08 in.)
Height	338 mm (13.28 in.)
Width	545 mm (26.4 in.)
Mass Specific Density	5.08 Nm/kg
Torque Specific Density	.197 kg/Nm

* **ETM** = Electronic Throttle Management for prime mover, taking its input from the VHRL.

VHRL = Varadrive High Ratio Electronic Limiter which controls the actual ratios due to extreme drive ratios near engaged neutral.



VMT Technologies, LLC
Novell Technology Center
34 East 1700 South, Suite A-141
Provo, UT 84606
801-228-1510 801-504-8227 fax
engineering@vmt-tech.com

Note: Use of vehicle pictures is for vehicle class illustrative purposes only and does not constitute an endorsement of the Universal Transmission by the respective manufacturers.